

## PRESSURE, VACUUM &amp; DIFFERENTIAL PRESSURE

**FEATURES**

- Brass, Polysulfone® (FDA approved), and PFA Teflon® Pressure Connections
- Compact Size: 3.5" x 2.5" x 2.3"
- Complies with Enclosure Type 4 with watertight conduit fitting
- Terminal block wiring
- Optional red status light
- Adjustable Ranges:

Pressure: 30" Hg Vac to 90 psi  
(-1 to 6,2 bar)

Differential Pressure: 1 to 45 psid  
(68,9 mbar to 3,1 bar)



### OVERVIEW

The 24 Series Delta-Pro™ pressure, differential pressure and vacuum switches offer a unique blend of compact size, excellent performance, environmental protection and attractive price. Available with brass, polysulfone®, or PFA Teflon® pressure connections the Delta-Pro will stand up in your most corrosive applications. The precision snap-acting switch and sensitive diaphragms combine to provide a narrow deadband and repeatability of approximately  $\pm 1\%$  of range span. The convenient, externally accessible adjustment screw is multi-turn to provide easy set point adjustability. The force-balanced design gives the Delta-Pro excellent vibration resistance.

### FEATURES

- UL listed and cUL certified. CE compliant to low voltage directive and pressure equipment directive
- Vacuum, Pressure or Differential pressure measurement
- 5 A @ 125/250 VAC SPDT snap-acting switch
- External stainless steel multi-turn adjusting screw
- OEM capabilities include external adjustment knob with or without reference scale

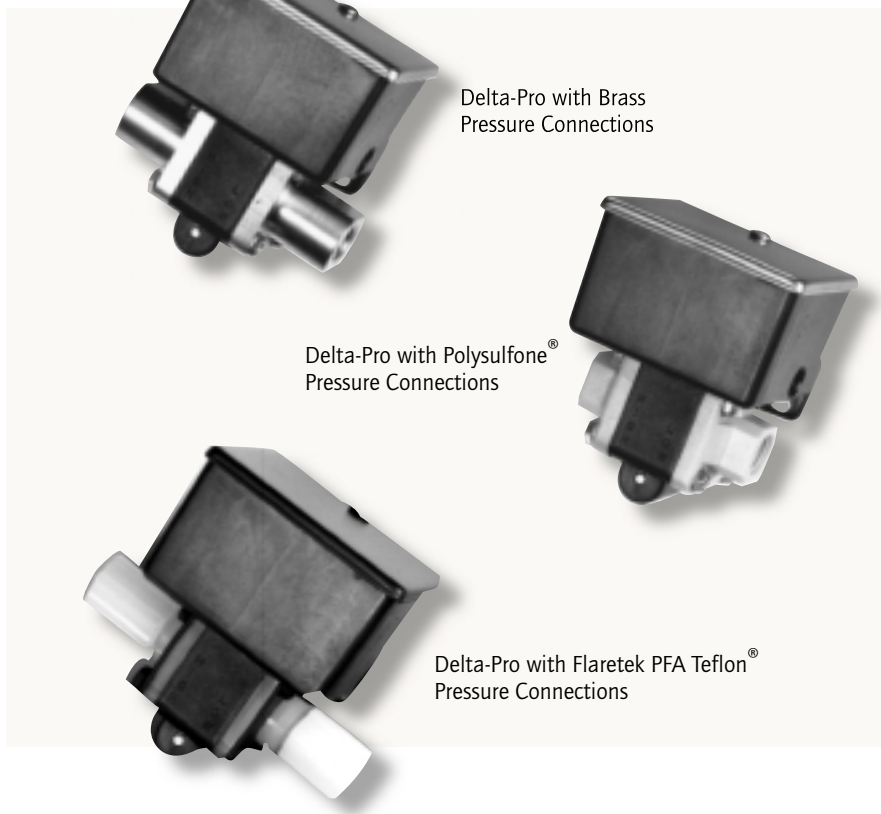

## APPLICATIONS

Typical applications include filter monitoring and proof-of-flow. High purity versions may also be used to monitor and control deionized water systems, wet benches, cleaning equipment, corrosive gas lines and bulk chemical handling systems.

## TECHNOLOGY

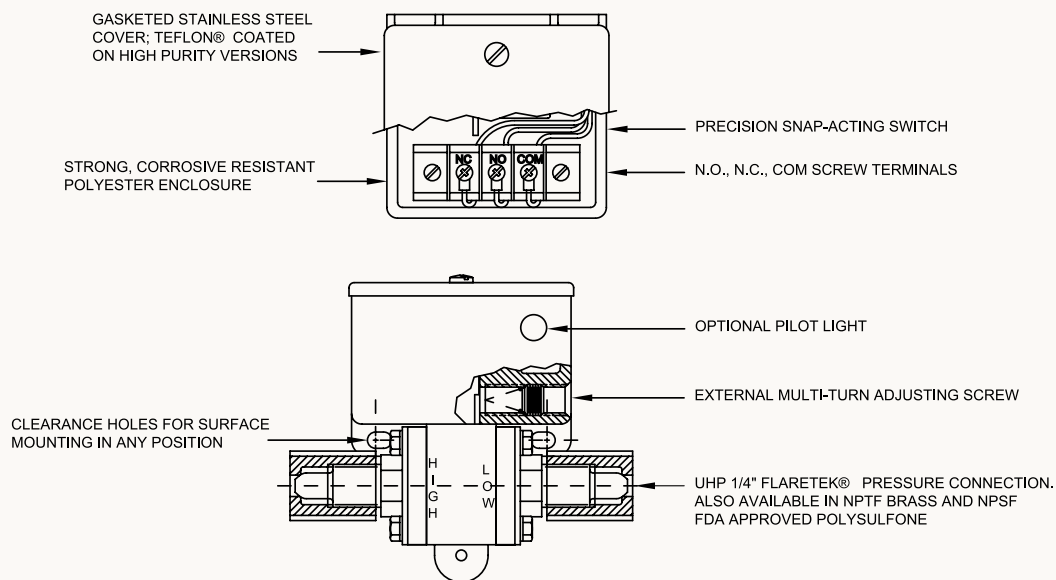

The 24 Series (also known as the Delta Pro™) was designed to be a compact, cost-effective differential pressure switch for applications such as proof-of-flow, filter monitoring, etc. It depends on two opposing diaphragms to sense pressure on the "High" and "Low" pressure outputs of a system. The resulting pressure differential is transmitted through a linkage to a snap-action electrical switch, providing an output when a pre-set difference is exceeded. This set point can be easily modified while under pressure via an external adjusting screw. This adjustment "pre-loads" the actuation mechanism, which results in excellent vibration-resistance. Straight pressure and vacuum versions, with a single diaphragm, are also available.



# 24 Series

## 24 Series

### SPECIFICATIONS

|                                    |                                                                                                                                                                                                                                                                                                                                                                                                                                        |
|------------------------------------|----------------------------------------------------------------------------------------------------------------------------------------------------------------------------------------------------------------------------------------------------------------------------------------------------------------------------------------------------------------------------------------------------------------------------------------|
| <b>STORAGE TEMPERATURE</b>         | -20° to 180°F (-29° to 82°C)                                                                                                                                                                                                                                                                                                                                                                                                           |
| <b>AMBIENT TEMPERATURE</b>         | 30° to 160°F (-1° to 71°C). Set point typically shifts less than ±0.6% of range for a 50°F (28°C) ambient temperature change; consult factory for special ratings                                                                                                                                                                                                                                                                      |
| <b>MAX MEDIA TEMPERATURE</b>       | 200°F (93°C) at 100 psi working pressure;<br>160°F (71°C) at 100 psi working pressure for models 030, 031                                                                                                                                                                                                                                                                                                                              |
| <b>SHOCK</b>                       | Set point repeats after 15G, 10 millisecond duration.                                                                                                                                                                                                                                                                                                                                                                                  |
| <b>VIBRATION</b>                   | Set point repeats after 2.5 G, 5-500 Hz                                                                                                                                                                                                                                                                                                                                                                                                |
| <b>ENCLOSURE CLASSIFICATION</b>    | Complies with enclosure type 4 requirements with optional water tight conduit connector. Reinforced polyester body, stainless steel cover with neoprene gasket. Note: All external hardware Teflon® coated on models 030 and 031                                                                                                                                                                                                       |
| <b>SET POINT REPEATABILITY</b>     | Typically ± 1% of span.                                                                                                                                                                                                                                                                                                                                                                                                                |
| <b>SWITCH OUTPUT</b>               | One SPDT precision snap-acting micro-switch with mechanical contact life of 10 million cycles. Actual life depends on electrical load and cycle frequency                                                                                                                                                                                                                                                                              |
| <b>ELECTRICAL RATING</b>           | Rated to 5 A resistive and 5 A inductive (75% PF) at 125 VAC and 250 VAC, 1/4 HP; 5 A resistive and 3 A inductive at 30 VDC and 0.5 A resistive and 0.25 inductive at 125 VDC. Gold clad silver contacts for minimum loads of 5 mA at 6 VDC, 2 mA at 12 VDC and 1 mA at 24 VDC                                                                                                                                                         |
| <b>WEIGHT</b>                      | 6.5 oz.                                                                                                                                                                                                                                                                                                                                                                                                                                |
| <b>ELECTRICAL CONNECTION</b>       | 7/8" hole for optional 1/2" NPT conduit connector. Terminal block with screw terminals. Max wire size 16 AWG                                                                                                                                                                                                                                                                                                                           |
| <b>PRESSURE CONNECTION</b>         | Models 013-014, 019-022: 1/4" NPT (female) brass; models 011-012, 015-018: 1/4" NPS (female) FDA approved polysulfone®, non-tapered to minimize connection stress with 1/4" NPT (male) fittings - max torque is 2-ft.lbs; models 030-031; 1/4" Flaretek® style connections with nuts provided, offers high vibration, leak resistant connections with minimal dead volume. Flaretek® fittings are PFA Teflon® and nuts are PVD Teflon® |
| <b>MOUNTING &amp; INSTALLATION</b> | Surface mount with two screws through clearance holes, or mount by pressure connections                                                                                                                                                                                                                                                                                                                                                |

Teflon® is a registered trademark of E.I. Dupont Company. Flaretek® is a registered trademark of Fluoroware, Inc  
Polysulfone® is a registered trademark of Amoco.

### APPROVALS



#### **UNITED STATES AND CANADA**

**UL** Listed, **cUL** Certified

Pressure: UL 508; CSA C22.2 No. 14, File #E42272



#### **EUROPE**

**CENELEC/TÜV** Süddeutschland Bau und Betrieb GmbH (N.B. #0036)

**TÜV** certified to PED (97/23/EC) (**OPTIONAL Code M407**)

Category IV, Module H1

Certificate #USA 02/04/38/001 thru USA 02/07/38/033

UEC Compliant to LVD (73/23/EC & 93/68/EEC)

Products rated lower than 50 VAC and 75 VDC are outside of the scope of the LVD

## DIFFERENTIAL PRESSURE MODEL CHART

| Model                                                                                                  | Adjustable Range         |                           | Typical Deadband |      | ***Max. Working Pressure |           | **Proof Pressure |      |
|--------------------------------------------------------------------------------------------------------|--------------------------|---------------------------|------------------|------|--------------------------|-----------|------------------|------|
|                                                                                                        | Low end of range of fall | High end of range on rise | psid             | mbar | psi                      | bar       | psi              | bar  |
| Polyurethane (polyether) diaphragm and polysulfone® 1/4" NPS (female) (mechanical) pressure connection |                          |                           |                  |      |                          |           |                  |      |
| 011                                                                                                    | 1 to 10                  | 68,9 mbar to 0,7          | 0.75             | 51,7 | 0 to 150                 | 0 to 10,3 | 150              | 10,3 |
| 012                                                                                                    | 4 to 45                  | 0,3 to 3,1                | 1                | 68,9 | 0 to 150                 | 0 to 10,3 | 150              | 10,3 |
| Polyurethane (polyether) diaphragm and brass 1/4" NPT (female) pressure connection                     |                          |                           |                  |      |                          |           |                  |      |
| 013                                                                                                    | 1 to 10                  | 68,9 mbar to 0,7          | 0.75             | 51,7 | 0 to 150                 | 0 to 10   | 150              | 10,3 |
| 014                                                                                                    | 4 to 45                  | 0,3 to 3,1                | 1                | 68,9 | 0 to 150                 | 0 to 10   | 150              | 10,3 |
| PFA Teflon® diaphragm and PFA Teflon® 1/4" Flaretek® pressure connection. (PVD Teflon® nuts provided)  |                          |                           |                  |      |                          |           |                  |      |
| 030                                                                                                    | 1 to 10                  | 68,9 mbar to 0,7          | 0.75             | 51,7 | 0 to 100                 | 0 to 6,9  | 100              | 6,9  |
| 031                                                                                                    | 4 to 45                  | 0,3 to 3,1                | 1                | 68,9 | 0 to 100                 | 0 to 6,9  | 100              | 6,9  |

## VACUUM AND PRESSURE MODEL CHART

| Model                                                                                                   | Adjustable Range |                      | Typical Deadband |         | *Over Range Pressure |      | **Proof Pressure |      |
|---------------------------------------------------------------------------------------------------------|------------------|----------------------|------------------|---------|----------------------|------|------------------|------|
|                                                                                                         | psi              | bar                  | psi              | mbar    | psi                  | bar  | psi              | bar  |
| Polyurethane (polyether) diaphragm and polysulfone®, 1/4" NPS (female) (mechanical) pressure connection |                  |                      |                  |         |                      |      |                  |      |
| 015                                                                                                     | 30" to 2" Hg VAC | -1 bar to -68,9 mbar | 2.5" Hg          | -84,7   | 150                  | 10,3 | 150              | 10,3 |
| 016                                                                                                     | 1 to 10          | 68,9 mbar to 0,7     | 0.75             | 51,7    | 150                  | 10,3 | 150              | 10,3 |
| 017                                                                                                     | 4 to 45          | 0,3 to 3,1           | 1                | 68,9    | 150                  | 10,3 | 150              | 10,3 |
| 018                                                                                                     | 10 to 90         | 0,7 to 6,2           | 3                | 0,2 bar | 150                  | 10,3 | 150              | 10,3 |
| Polyurethane (polyether) diaphragm and brass 1/4" NPT (female) pressure connection                      |                  |                      |                  |         |                      |      |                  |      |
| 019                                                                                                     | 30" to 2" Hg VAC | -1 bar to -68,9 mbar | 2.5" Hg          | -84,7   | 150                  | 10,3 | 10               | 10,3 |
| 020                                                                                                     | 1 to 10          | 68,9 mbar to 0,7     | 0.75             | 51,7    | 150                  | 10,3 | 150              | 10,3 |
| 021                                                                                                     | 4 to 45          | 0,3 to 3,1           | 1                | 68,9    | 150                  | 10   | 150              | 10,3 |
| 022                                                                                                     | 10 to 90         | 0,7 to 6,2           | 3                | 0,2 bar | 150                  | 10,3 | 150              | 10,3 |

**\*Over Range Pressure:** The maximum pressure that may be applied continuously without causing damage and maintaining set point repeatability.

**\*\*Proof Pressure:** The maximum pressure to which a pressure sensor may be occasionally subjected, which causes no permanent damage. The unit may require calibration (e.g. start-up, testing).

**\*\*\*Working Pressure:** The pressure range within which two opposing sensors can be safely operated and still maintain set point adjustability provided the difference in pressure between them does not exceed the designated adjustable range.



### HOW TO ORDER

Build a part number by selecting a model and options. Choose the Sensor Type and the Range from the Model Chart. If options are required, add the code from the option list below. Example: 24 030 \* M900.

|                            |                              |                                 |
|----------------------------|------------------------------|---------------------------------|
| <b>24</b><br>Select a Type | <b>030</b><br>Select a Model | <b>M900</b><br>Select an Option |
| 24                         | 030                          | M900                            |

#### COMPONENTS CODE

#### DESCRIPTION

#### SERIES DESIGNATION

24 Designation for 24 Series product line

#### DIFFERENTIAL PRESSURE MODELS \*

011, 012 Polyurethane (polyether) diaphragm and 1/4" NPS (female) (mechanical) polysulfone® pressure connection

013, 014 Polyurethane (polyether) diaphragm and 1/4" NPT (female) brass pressure connection

030, 031 PFA Teflon® diaphragm and 1/4" Flaretek® PFA Teflon® pressure connection  
\*(See Model Chart for Differential Pressure Ranges)

#### VACUUM AND PRESSURE MODELS \*

015, 016, 017, 018 Polyurethane (polyether) diaphragm and 1/4" NPS (female) (mechanical) polysulfone pressure connection

019, 020, 021, 022 Polyurethane (polyether) diaphragm and 1/4" NPT (female) brass pressure connection  
\*(See Model Chart for Pressure Ranges)

#### OPTIONS

M020 Red status light, 115 VAC only. Specify whether light turns on or off with increasing or decreasing pressure

M201 Factory set one switch; specify increasing or decreasing pressure and set point

M260 Self-contained battery-operated audible alarm

M262 Buna-N diaphragm: not available on models 030, 031

M277 Range indicated on nameplate in kPa or MPa

M278 Range indicated on nameplate in Kg/cm<sup>2</sup>

M407 CE Compliance to Pressure Equipment Directive (category IV) NOT AVAILABLE MODELS 015, 019, 030, 031

M540 Viton® construction (deadbands and low end of range may increase slightly. Consult factory.) Wetted parts include Viton® diaphragm plus standard connection material. NOT AVAILABLE ON MODELS 030, 031

M900 Water tight conduit fitting; converts 7/8" hole to 1/2" NPT fitting; must specify for Enclosure Type 4 compliance

# DIMENSIONAL DRAWINGS

Dimensional drawings for all models may be found at [www.ueonline.com](http://www.ueonline.com)

## Models 011, 012, 013 & 014

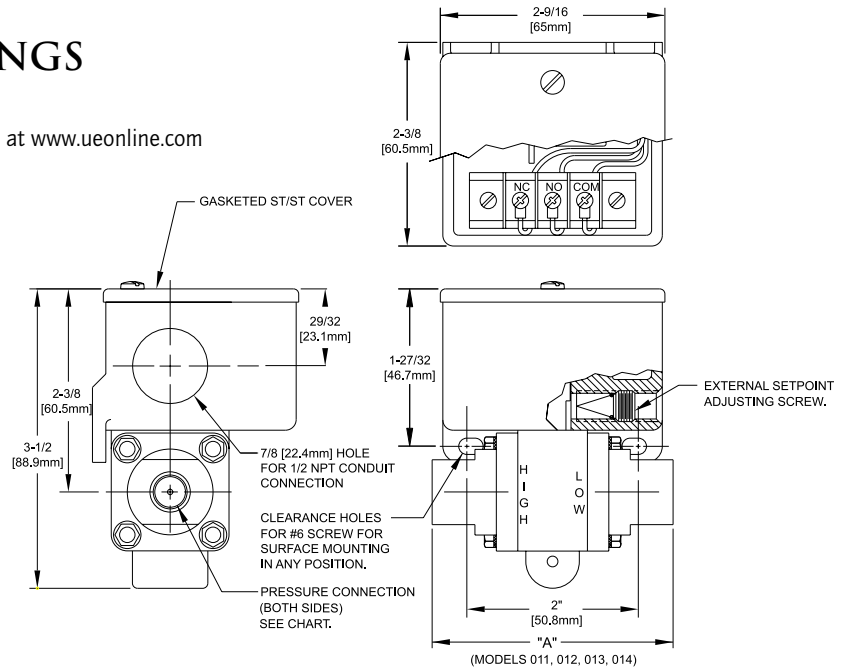

All dimensions stated in inches (millimeters)

## Models 015 & 019

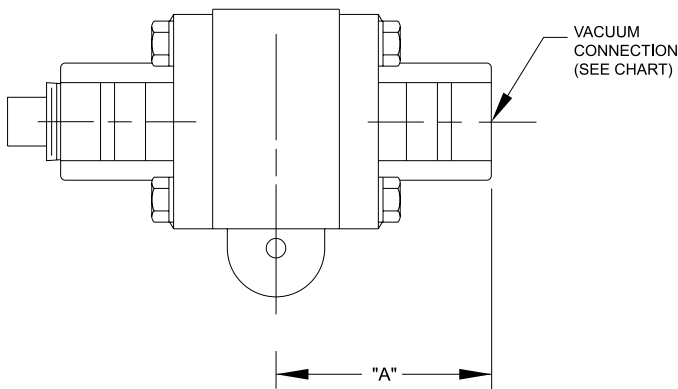

## Models 016, 017, 018, 020, 021 & 022

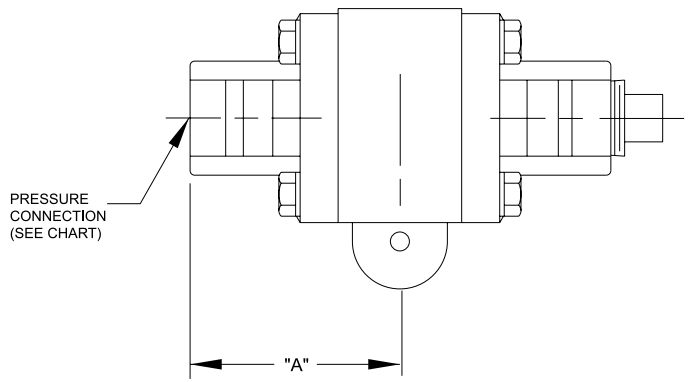

## Models 030 & 031

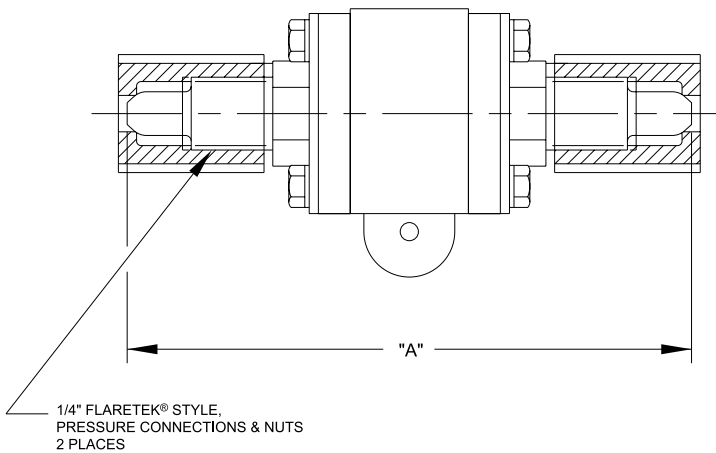

| Model              | DIMENSION A      | Pressure Connection      |
|--------------------|------------------|--------------------------|
| 011, 012           | 2.75" (69.9 mm)  | 1/4" NPS (F) Polysulfone |
| 013, 014           | 3.13" (79.5 mm)  | 1/4" NPT (F) Brass       |
| 015, 016, 017, 018 | 1.44" (36.6 mm)  | 1/4" NPS (F) Polysulfone |
| 019, 020, 021, 022 | 1.56" (39.6 mm)  | 1/4" NPT (F) Brass       |
| 030, 031           | 4.00" (101.6 mm) | 1/4" Flaretek® Teflon    |

1/4" FLARETEK® STYLE,  
PRESSURE CONNECTIONS & NUTS  
2 PLACES

## RECOMMENDED PRACTICES AND WARNINGS

United Electric Controls Company recommends careful consideration of the following factors when specifying and installing UE pressure and temperature units. Before installing a unit, the Installation and Maintenance instructions provided with unit must be read and understood.

- To avoid damaging unit, proof pressure and maximum temperature limits stated in literature and on nameplates must never be exceeded, even by surges in the system. Operation of the unit up to maximum pressure or temperature is acceptable on a limited basis (e.g., start-up, testing) but continuous operation must be restricted to the designated adjustable range. Excessive cycling at maximum pressure or temperature limits could reduce sensor life.
- A back-up unit is necessary for applications where damage to a primary unit could endanger life, limb or property. A high or low limit switch is necessary for applications where a dangerous runaway condition could result.
- The adjustable range must be selected so that incorrect, inadvertent or malicious setting at any range point cannot result in an unsafe system condition.
- Install unit where shock, vibration and ambient temperature fluctuations will not damage unit or affect operation. When applicable, orient unit so that moisture does not enter the enclosure via the electrical connection. When appropriate, this entry point should be sealed to prevent moisture entry.
- Unit must not be altered or modified after shipment. Consult UE if modification is necessary.
- Monitor operation to observe warning signs of possible damage to unit, such as drift in set point or faulty display. Check unit immediately.
- Preventative maintenance and periodic testing is necessary for critical applications where damage could endanger property or personnel.
- Electrical ratings stated in literature and on nameplate must not be exceeded. Overload on a switch can cause damage, even on the first cycle. Wire unit according to local and national electrical codes, using wire size recommended in installation sheet.
- Do not mount unit in ambient temp. exceeding published limits.

## LIMITED WARRANTY

Seller warrants that the product hereby purchased is, upon delivery, free from defects in material and workmanship and that any such product which is found to be defective in such workmanship or material will be repaired or replaced by Seller (Ex-works, Factory, Watertown, Massachusetts. INCOTERMS); provided, however, that this warranty applies only to equipment found to be so defective within a period of 24 months from the date of manufacture by the Seller. Seller shall not be obligated under this warranty for alleged defects which examination discloses are due to tampering, misuse, neglect, improper storage, and in any case where products are disassembled by anyone other than authorized Seller's representatives. EXCEPT FOR THE LIMITED WARRANTY OF REPAIR AND REPLACEMENT STATED ABOVE, SELLER DISCLAIMS ALL WARRANTIES WHATSOEVER WITH RESPECT TO THE PRODUCT, INCLUDING ALL IMPLIED WARRANTIES OF MERCHANTABILITY OR FITNESS FOR ANY PARTICULAR PURPOSE.

## LIMITATION OF SELLER'S LIABILITY

Seller's liability to Buyer for any loss or claim, including liability incurred in connection with (i) breach of any warranty whatsoever, expressed or implied, (ii) a breach of contract, (iii) a negligent act or acts (or negligent failure to act) committed by Seller, or (iv) an act for which strict liability will be inputted to seller, is limited to the "limited warranty" of repair and/or replacement as so stated in our warranty of product. In no event shall the Seller be liable for any special, indirect, consequential or other damages of a like general nature, including, without limitation, loss of profits or production, or loss or expenses of any nature incurred by the buyer or any third party.

*UE specifications subject to change without notice.*

## U.S. SALES OFFICES

United Electric Controls  
32 Highland Rd.  
South Hampton, NH 03827  
Phone: 603-394-0078  
FAX: 603-394-0175

United Electric Controls  
28 N. Wise Ave.  
Freeport, IL 61032  
Phone: 815-235-3501  
FAX: 815-235-3847

United Electric Controls  
1022 Vineyard Drive  
Conyers, GA 30013  
Phone: 770-483-8400  
FAX: 770-929-8716

United Electric Controls  
5829 Grazing Court  
Mason, OH 45040  
Phone: 513-398-3175  
FAX: 513-398-3076

United Electric Controls  
102 Salazar Court  
Clayton, CA 94517  
Phone: 925-524-0210  
FAX: 925-524-0210

United Electric Controls  
27 Summit Terrace  
Sparta, NJ 07871  
Phone: 973-271-2550  
FAX: 973-729-6099

United Electric Controls  
12630 Summerwood Glen  
Houston, TX 77041  
Phone: 832-243-0119  
FAX: 832-243-0140

## CANADA

EASTERN  
68 Mosley Crescent  
Brampton, Ontario  
Canada L6Y 5C8  
Phone: 905-455-5131  
FAX: 905-455-5131

## INTERNATIONAL OFFICES

BELGIUM  
United Electric Controls-Europe  
G. Van Gervenstraat 19A  
B-9120 Beveren-Waas, Belgium  
Phone: 32-37554-383  
FAX: 32-37552-747

CHINA  
United Electric Controls  
Room 1114, No. 511  
Shenshi Building  
Weihai Road  
Shanghai 200041, P.R. China  
Phone: +8621-6255 8059  
FAX: +8621-6255 8349

GERMANY  
United Electric Controls  
An Der Zentlinde 21  
D-64711 Erbach, Germany  
Phone: 496-062-7400  
FAX: 496-062-7501

MALAYSIA  
United Electric Controls, Far East  
No. 1-2-2, 2nd Floor  
Jalan 4/101C  
Cheras Business Centre  
Batu 5, Jalan Cheras  
56100 Kuala Lumpur, Malaysia  
Phone: 603-9133-4122  
FAX: 603-9133-4155

MEXICO  
United Electric Controls  
Andador Austria 102  
Fracc. Petroquimica CP 89365  
Tampico, Tamaulipas Mexico  
Phone: 833-132-3726  
FAX: 833-132-3726

RUSSIA  
United Electric Controls, Moscow  
Kuisinena str., 19A, Office 310  
Moscow, 125252, Russia  
Phone: +7 (095) 792-88-06  
FAX: +7 (095) 258-92-12

WESTERN  
148 Silver Ridge Close N.W.  
Calgary, Alberta  
Canada T3B 3T4  
Phone: 403-247-3724  
FAX: 403-247-3724



UNITED ELECTRIC  
CONTROLS

180 Dexter Avenue, P.O. Box 9143  
Watertown, MA 02471-9143 USA  
Telephone: 617 926-1000 Fax: 617 926-2568  
<http://www.ueonline.com>